



Received: 19 October 2015
Accepted: 01 April 2016
Published: 06 May 2016

*Corresponding author: Jean-Luc Rebière, Laboratoire d'Acoustique de l'Université du Maine, LAUM (UMR CNRS 6613), Université du Maine, Avenue Olivier Messiaen, 72085 Le Mans Cedex 9, France
E-mail: jean-luc.rebiere@univ-lemans.fr

Reviewing editor:
Eileen Harkin-Jones, Queen's University Belfast, UK

Additional information is available at the end of the article

MATERIALS ENGINEERING | RESEARCH ARTICLE

The initiation of transverse matrix cracking and longitudinal matrix cracking in composite cross-ply laminates: Analysis of a damage criterion

Jean-Luc Rebière^{1*}

Abstract: The results of stress field distribution in damage cross-ply laminates prompt us to elaborate an energy criterion. This criterion is based on the partial parts's computation of the strain energy release rate associated with each damage type and for all loading modes. In the related criterion, based on the linear fracture approach, several hypotheses are used to simplify the damage criterion. The main objective with this approach is to estimate the onset of transverse and longitudinal cracking mechanisms and the development of the damage. Only results from numerical simulations are proposed for one material; numerous numerical simulations, with other materials and laminate architectures, give similar evolutions of matrix cracking damage.

Subjects: Composite Materials; Composites; Material Fracture Mechanics

Keywords: composite laminates; transverse cracking; longitudinal cracking; failure criterion

1. Introduction

In the transport industry, aeroplanes, automobiles, trains, boats, and designers need good estimates of the performance of structural parts made from composite materials with long fibre and polymer matrix. In laminates subjected to both static and fatigue loading, several damage modes, such as matrix cracking, delamination or fibre break may appear in turn. Although composite



Jean-Luc Rebière

ABOUT THE AUTHOR

LAUM (Acoustics Laboratory of the Université du Maine) is a Co-educational Research unit of the Université du Maine and of the CNRS (UMR 6613). The enrollment of the laboratory is about 140 people. The activities of the Laboratory are focused in most cases on "audible" acoustics but the laboratory has inserted new research topics for some years in the field of vibrations and ultrasounds in materials. Studies concern the spread of waves in fluids and in the solid as well as on the mechanisms of coupling. They have as object to understand physical phenomena by favouring the development of analytical models and of experimental studies linked to necessary numerical simulation. Researchers are performed as part of three teams specialized on complementary themes: Materials, Transducers, Vibrations, Guided Acoustics and Flow. Theme development in the team materials are Bio Composite Material and Structural Health Monitoring.

PUBLIC INTEREST STATEMENT

Composites materials are used in many structural applications: aerospace, aeronautics, automobile, sport, etc. It is therefore necessary to predict whether these structures will be able to resist to all the applied stresses. So, a damage criterion was elaborate to evaluate the damage evolution in composite structures. We can estimate the sequence of initiation of the damage (transverse cracking and longitudinal cracking) which depends on the main parameters: material constituent system, stacking sequence, loading history, etc. The main objective of this paper is to propose appropriate approximations of the strain energy release rates for each type of damage (transverse cracking and longitudinal cracking) for the three damage modes (mode I (opening mode), mode II (sliding mode) and mode III (tearing mode)).

laminates are extensively used in many structural applications because of their high strength to weight ratio, their durability still needs to be carefully assessed. For this purpose, it is desirable to be able to rely on a suitable damage-growth criterion. The objective of this work is to evaluate the transition between the different types of damage and to study their evolution. So, we propose an energy criterion for evaluating the onset of transverse matrix cracking and longitudinal matrix cracking in composite cross-ply laminates.

The main objective of this study, which is new, is to analyse the total energy criterion in order to determine the threshold of various damage modes. This energy criterion method is based on the computation of the strain energy release rate of the whole laminate associated with each damage mode. With this criterion, we have analysed the strain energy release rates of the whole laminate in order to separate component parts related to each component of the stress tensor on one hand and, on the other hand, with these results, the different damage mechanisms for each loading mode (*mode I, mode II or mode III*) are considered. With the damage criterion, the originality is that the total strain energy release rate is replaced by the part of it which is directly related to one specific damage mechanism. For each damage mechanism, the contributions of the loading modes have also been separated.

In the literature, a lot of work has been done to investigate the development of cracking damage in cross-ply laminates and several types of criteria have been proposed (Akshantala & Talreja, 2000; Brewer & Lagace, 1988; Dakshina Moorthy & Reddy, 1999; Hinton, Kaddour, & Soden, 2004; Nairn & Hu, 1992; Ogihara & Takeda, 1995; Pereira, de Moraes, Marques, & de Castro, 2004; Xia, Chen, & Ellyin, 2000), among them maximum are stress-based approaches. Other kinds of criteria (Rebière, 1992; Rebière & Gamby, 2004) rely on the energy release rates associated with each type of damage mode.

Experimentally, in cross-ply laminates subjected to uniaxial static or fatigue tensile loading, it was observed that the damage mechanisms sequences are as follows. The first type of damage is generally transverse matrix cracking. After transverse cracking damage, at the crack tip level, there is a high concentration of interlaminar stress. Generally, this high interlaminar stress causes on one hand the separation of the layers at ply interfaces with different directions, and/or on the other hand matrix cracking between fibres in the layers parallel to the loading axes. Longitudinal cracking and/or delamination are subsequent developments of transverse cracking damage. For some stacking sequences, the second damage observed is longitudinal damage.

In this article, the energy damage criterion has already been validated for the general case of the whole laminate. We propose an extension of the criterion with the analysis and its computation method. In this article, only results of numerical simulations are proposed for one material. For other materials, behaviours were investigated.

2. Model

2.1. Problem statement

The specimen studied is confined to a $[0_m, 90_n]_s$ composite cross-ply laminate as represented in Figure 1. The parameters used to describe the laminate architecture are the λ coefficient ($\lambda = t_0/t_{90}$ where t_0 is the 0° ply thickness and t_{90} is the 90° ply thickness) and the thicknesses of the 0° and 90° plies. The middle plane (*xoy plane*) of the laminate is a symmetrical plane.

Methodology: To evaluate the strain energy release rates, the laminate is assumed to have been previously damaged by transverse and/or longitudinal cracks (Figures 1 and 2). The accepted assumptions for the crack geometries in the two layers of the laminate are as follows: all the cracks are assumed to have a rectangular plane geometry, and each crack extends over the whole thickness and the whole width of the 90° damaged ply. Similar assumptions are made for the longitudinal cracks in the 0° layers. Moreover, crack distribution is assumed to be uniform along both *x* and *y* axes. With these assumptions, it is sufficient to study the “Unit damaged cell” represented in Figure 2. This “Unit

Figure 1. Laminate damaged by transverse and longitudinal cracks.

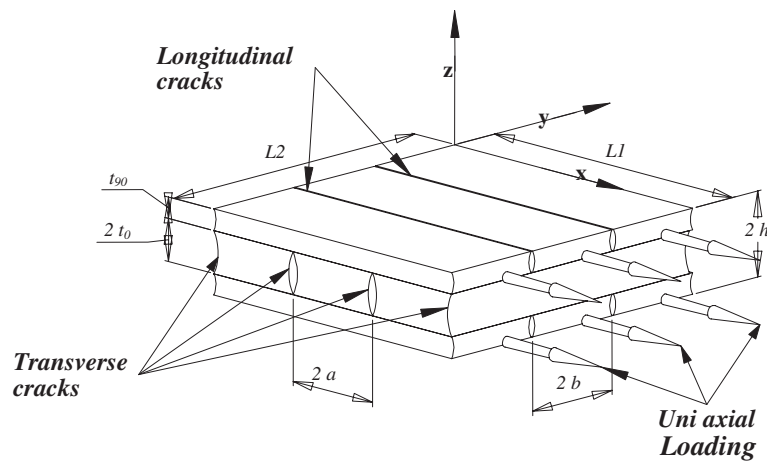
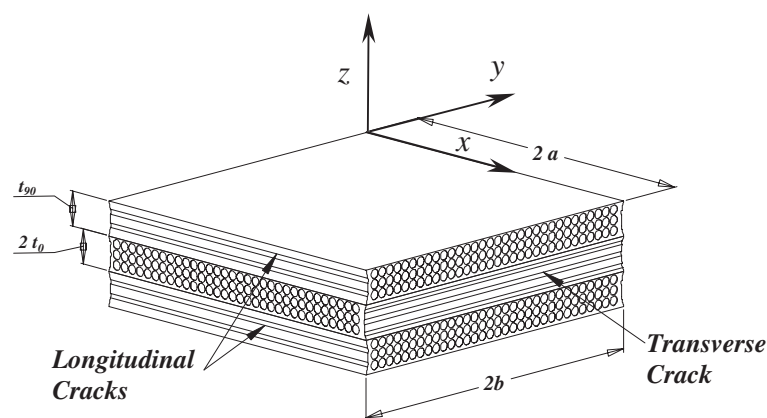

Figure 2. Unit damaged cell located between two transverse cracks and two longitudinal cracks.



damaged cell” lies between two consecutive transverse cracks and two consecutive longitudinal cracks. We are giving a summary of the method used to estimate the stress field distribution in the cracked and delaminated laminate. The analytical model is based on a variational approach relying on the proper choice of a statically admissible stress field. In the damaged laminate, the stress field in the two layers has the following form:

$$\sigma_{ij}^{T(k)} = \sigma_{ij}^{0(k)} + \sigma_{ij}^{P(k)} \tag{1}$$

For the undamaged laminate loaded on the x axis, the layers undergo a uniform plane stress state $\sigma_{ij}^{0(k)}$ obtained by the laminate plate theory (where k is the ply index, $k = 0^\circ, 90^\circ$). The orthogonal cracks induce stress perturbations in the 0° and 90° layers which are denoted $\sigma_{ij}^{P(k)}$ (Rebière, Maâtallah, & Gamby, 2001).

2.2. Strain energy release rate

For a given stress state, the strain energy release rate G associated with the initiation and development of the crack damage or delamination damage is defined by the following expression:

$$G = \frac{d}{dA} \tilde{U}(\sigma, A) \quad \text{with} \quad \tilde{U}_d = N.M.U_{cel} \tag{2}$$

where \tilde{U}_d is the strain energy of the whole laminate and A is the cracked area. Let L_1 denote the laminate length on the x axis, L_2 being its width on the y axis (Figure 1). The strain energy in the damaged unit cell is denoted by U_{cel} . $N(N = L_1/2\bar{a}t_{90^\circ})$ is the number of transverse cracks and $M(M = L_2/2\bar{b}t_{90^\circ})$ is the number of longitudinal cracks. Using dimensionless quantities, $\bar{x} = x/t_{90^\circ}$, $\bar{y} = y/t_{90^\circ}$, $\bar{z} = z/t_{90^\circ}$

$\bar{h} = h/t_{90}$, $\bar{a} = a/t_{90}$, $\bar{b} = b/t_{90}$ and the constraining parameter is $\lambda = t_0/t_{90}$. The transverse crack density is defined by d_t ($d_t = 1/2a$) and the longitudinal crack density is d_l ($d_l = 1/2b$). A_f represents the crack area ($A_f = L_1L_2(1/\bar{a} + \lambda/\bar{b})$).

The strain energy release rate associated with transverse cracking is denoted G_{FT} . The strain energy release rate related with longitudinal cracking is denoted G_{FL} .

$$G_{FT} = \frac{d\tilde{U}_d}{dA_f} = \frac{d\tilde{U}_d}{d\bar{a}} \cdot \frac{d\bar{a}}{dA_f} \quad G_{FL} = \frac{d\tilde{U}_d}{dA_f} = \frac{d\tilde{U}_d}{d\bar{b}} \cdot \frac{d\bar{b}}{dA_f} \quad (3)$$

$$G_{FT} = \frac{1}{2\bar{b}t_{90}^2} \left(U_{cel} - \bar{a} \frac{dU_{cel}}{d\bar{a}} \right) \quad G_{FL} = \frac{1}{2\bar{a}t_{90}^2\lambda} \left(U_{cel} - \bar{b} \frac{dU_{cel}}{d\bar{b}} \right) \quad (4)$$

2.3. Analysis of the strain energy release rate

The strain energy (2) is decomposed in order to obtain the contributions of all the component products of the stress tensor to the strain energy. The \tilde{U}_{ij} are related to the products in pairs of the components of the stress tensor as given in the following expression:

$$\tilde{U}_{ij} = 2.N.M. \left(U_{ij}^{90} + U_{ij}^0 \right) = \frac{L_1L_2}{2\bar{a}\bar{b}t_{90}} \left(U_{ij}^{90} + U_{ij}^0 \right) = \frac{L_1L_2}{2\bar{a}\bar{b}t_{90}} U_{ij} \quad (5)$$

where the eight parts of the energy $\tilde{U}_{ij}^{k_i}$ s are defined by:

$$\begin{aligned} U_1^{90} = U_{xx}^{90} &= \frac{1}{2E_T} \iiint_{V_{90}} \sigma_{xx}^{(90)^2} d\bar{x}d\bar{y}d\bar{z} & U_1^0 = U_{xx}^0 &= \frac{1}{2E_L} \iiint_{V_0} \sigma_{xx}^{(0)^2} d\bar{x}d\bar{y}d\bar{z} \\ U_2^{90} = U_{yy}^{90} &= \frac{1}{2E_L} \iiint_{V_{90}} \sigma_{yy}^{(90)^2} d\bar{x}d\bar{y}d\bar{z} & U_2^0 = U_{yy}^0 &= \frac{1}{2E_T} \iiint_{V_0} \sigma_{yy}^{(0)^2} d\bar{x}d\bar{y}d\bar{z} \\ U_3^{90} = U_{zz}^{90} &= \frac{1}{2E_T} \iiint_{V_{90}} \sigma_{zz}^{(90)^2} d\bar{x}d\bar{y}d\bar{z} & U_3^0 = U_{zz}^0 &= \frac{1}{2E_T} \iiint_{V_0} \sigma_{zz}^{(0)^2} d\bar{x}d\bar{y}d\bar{z} \\ U_4^{90} = U_{xx,zz}^{90} &= -\frac{\nu_{LT}}{E_L} \iiint_{V_{90}} \sigma_{xx}^{(90)} \sigma_{yy}^{(90)} d\bar{x}d\bar{y}d\bar{z} & U_4^0 = U_{xx,zz}^0 &= -\frac{\nu_{LT}}{E_L} \iiint_{V_0} \sigma_{xx}^{(0)} \sigma_{yy}^{(0)} d\bar{x}d\bar{y}d\bar{z} \\ U_5^{90} = U_{yy,zz}^{90} &= -\frac{\nu_{LT}}{E_L} \iiint_{V_{90}} \sigma_{yy}^{(90)} \sigma_{zz}^{(90)} d\bar{x}d\bar{y}d\bar{z} & U_5^0 = U_{yy,zz}^0 &= -\frac{\nu_{LT}}{E_L} \iiint_{V_0} \sigma_{yy}^{(0)} \sigma_{zz}^{(0)} d\bar{x}d\bar{y}d\bar{z} \\ U_6^{90} = U_{xx,zz}^{90} &= -\frac{\nu_{LT}}{E_L} \iiint_{V_{90}} \sigma_{xx}^{(90)} \sigma_{zz}^{(90)} d\bar{x}d\bar{y}d\bar{z} & U_6^0 = U_{xx,zz}^0 &= -\frac{\nu_{LT}}{E_L} \iiint_{V_0} \sigma_{xx}^{(0)} \sigma_{zz}^{(0)} d\bar{x}d\bar{y}d\bar{z} \\ U_7^{90} = U_{xz}^{90} &= \frac{1}{2G_{TT}} \iiint_{V_{90}} \sigma_{xz}^{(90)^2} d\bar{x}d\bar{y}d\bar{z} & U_7^0 = U_{xz}^0 &= -\frac{1}{2G_{LT}} \iiint_{V_0} \sigma_{xz}^{(0)^2} d\bar{x}d\bar{y}d\bar{z} \\ U_8^{90} = U_{yz}^{90} &= \frac{1}{2G_{LT}} \iiint_{V_{90}} \sigma_{yz}^{(90)^2} d\bar{x}d\bar{y}d\bar{z} & U_8^0 = U_{yz}^0 &= \frac{1}{2G_{TT}} \iiint_{V_0} \sigma_{yz}^{(0)^2} d\bar{x}d\bar{y}d\bar{z} \end{aligned} \quad (6)$$

The contribution of each selected component pair to the strain energy release rate is such that:

$$G_{ij}^k = \frac{d\tilde{U}_{ij}^k}{dx} \quad \text{where} \quad i = x, y, z \text{ and } k = 0^\circ, 90^\circ \quad (7)$$

The main objective of this paper is to propose appropriate approximations of the strain energy release rates for each type of damage (transverse cracking and longitudinal cracking) for the three damage modes (mode I (opening mode), mode II (sliding mode) and mode III (tearing mode)) (Lemaître & Chaboche, 1988/1990; Rebière & Gamby, 2004). We computed all the parts of the strain energy release rates that can be attributed to each stress component. Thus, the total strain energy release rate is replaced by only one of its components in (6) to describe the evolution of each damage mechanism and loading mode.

The estimation of the strain energy release rate, associated with the loading mode (mode I, II and III) (Mayes & Hansen, 2004) for the transverse crack damage (FT) and longitudinal crack damage (FL) are obtained with the following expressions:

$$\begin{aligned}
 G_I^{FT} &= \frac{d\tilde{U}_{xx}}{d\bar{a}} \cdot \frac{d\bar{a}}{dA_f} & G_{II}^{FT} &= \frac{d\tilde{U}_{xz}}{d\bar{a}} \cdot \frac{d\bar{a}}{dA_f} \\
 G_I^{FT} &= \frac{d\tilde{U}_{yy}}{d\bar{b}} \cdot \frac{d\bar{b}}{dA_f} & G_{II}^{FT} &= \frac{d\tilde{U}_{yz}}{d\bar{b}} \cdot \frac{d\bar{b}}{dA_f}
 \end{aligned}
 \tag{8}$$

We have estimated each one of the component of the strain energy release rates associated with each type of damage and for each fracture mode (8). To predict the evolution of the different damage mechanisms, a damage criterion is proposed. Each estimated quantity was compared to the associated critical value of the strain energy release rate.

$$G = G_c \tag{9}$$

For instance, observing the transverse cracking damage, we replaced the total strain energy release rate by the approximate quantity relative to the opening mode (*mode I*) and the sliding mode (*mode II*). The two computed values are compared to associated critical values G_{crf} . For example in Wang and Crossman (1980), Wang, Kishore, and Li (1985) G_{crf} values for a graphite epoxy system are given. Observing the initiation and development of other types of damage, longitudinal cracking and the transverse crack density is set in place. Concerning this crack density value, the partial strain energy release rates (8) are estimated. All the partial values are compared to critical values G_{crf} in the criterion (9). The strain energy release rates pertaining to each damage mechanism and mode are governed by the variation of this type of damage, other types of damage being imposed.

3. Results

The energy criterion proposed is as the elastic linear fracture-based approach. With this criterion, the analysis of the strain energy release rate associated with each type of damage is used. A by-product of this study is the assessment of the architecture and material system influence on the onset of transverse cracking and longitudinal cracking. The parameters used are the constraining parameter, the thickness of the two 0° and 90° layers and the constituent material system. The constraining parameter is λ ($\lambda = m/n$), where n is the number of plies at 90° and m is the number of plies at 0°. In all the proposed results, numerical simulations are carried out for a prescribed uniaxial loading of 150 MPa. The composite material system studied is a graphite/epoxy T300-934 system (see Table 1). In some numerical simulations, the partial parts of the strain energy release rates, associated with the onset of transverse cracking and longitudinal cracking are normalized by the critical strain energy release rate. The critical value of the strain energy release rate associated with transverse and longitudinal cracking initiation is denoted G_{crf} .

In Figure 3 the data pertains to a graphite/epoxy laminate and the results concern the analysis of the strain energy release rate versus the constraining parameter (λ). We note the evolution of the

Table 1. Mechanical properties and ply thickness for T300/934 graphite epoxy system

	Carbon/epoxy
E_{LT} (GPa)	140
E_{TT} (GPa)	10
G_{LT} (GPa)	5.7
G_{TT} (GPa)	3.6
ν_{LT}	0.31
ν_{TT}	0.58
Ply thickness (mm)	0.125
G_{crf} (J/m ²)	228

Figure 3. Variation of the partial part of the strain energy release rate for transverse damage versus the constraining parameter λ .

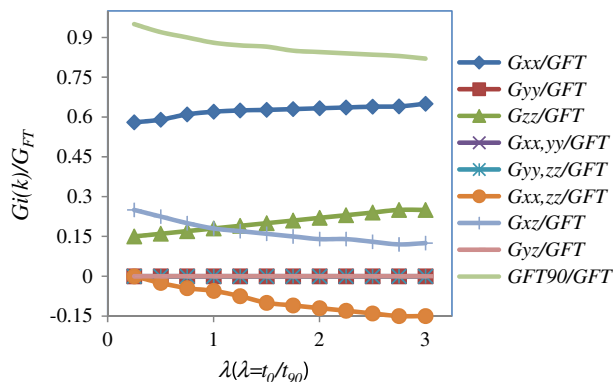
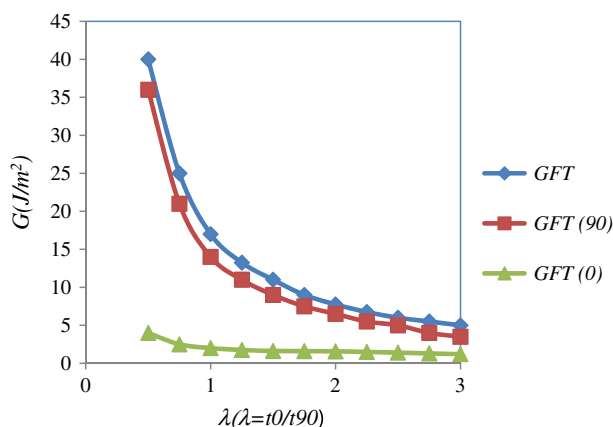

Figure 4. Variation of the layer contribution to the strain energy release rate ($G_{FT} = G_{FT}^0 + G_{FT}^{90}$), for transverse damage with the constraining parameter λ .



analysis of by-product in the 90° layer of the laminate versus the constraining parameter. The part due to stress in the loading direction of the laminate is overriding.

In Figure 4, the results to the numerical simulations confirm two main points: the proposed approach proves with experimental data that the initiation of transverse cracking is the first damage mode. It also predicts the readiness to initiate the three types of damage in the case of an eight-ply laminate containing a thick 90° layer.

The result in Figure 4 shows that the part attributed to the 90° is the most important part of the strain energy release rate. This value is reported on Figure 3 (the green curve).

Figure 5. Variation of the partial part of the strain energy release rate for longitudinal damage with the constraining parameter λ .

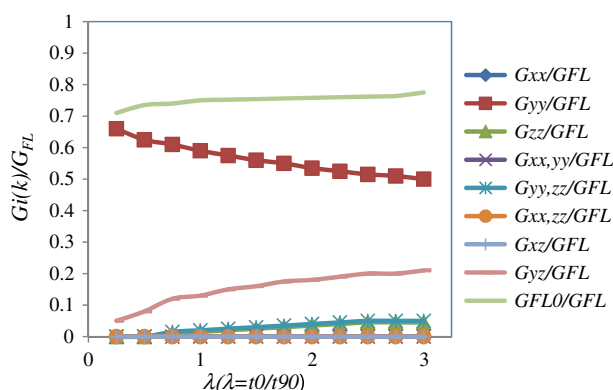

Table 2. Stress components with different mechanisms and loading modes

	Transverse cracking	Longitudinal cracking
Mode I	$\sigma_{xx}^{(90)}$	$\sigma_{yy}^{(0)}$
Mode II	$\sigma_{xz}^{(90)}$	$\sigma_{yz}^{(0)}$
Mode III	$\sigma_{xy}^{(90)}$	$\sigma_{xy}^{(0)}$

Figure 6. Variation of the layer contribution to the strain energy release rate ($G_{FL} = G_{FL}^0 + G_{FL}^{90}$), for transverse damage with the constraining parameter λ .

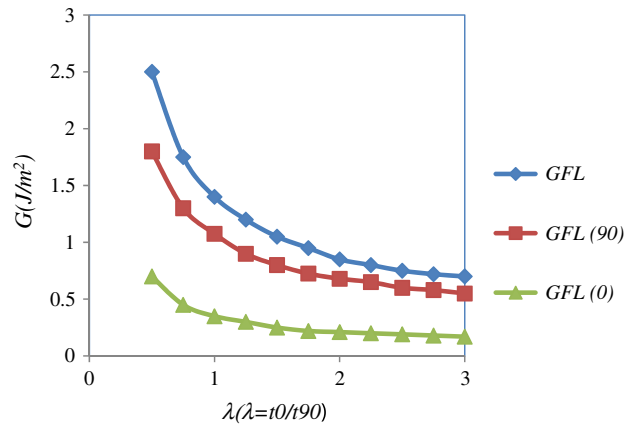

Figure 7. The onset of transverse cracks in a 8-ply laminate with constraining parameter λ is a result of the breaking modes G_I/G_{FT} G_{II}/G_{FT}

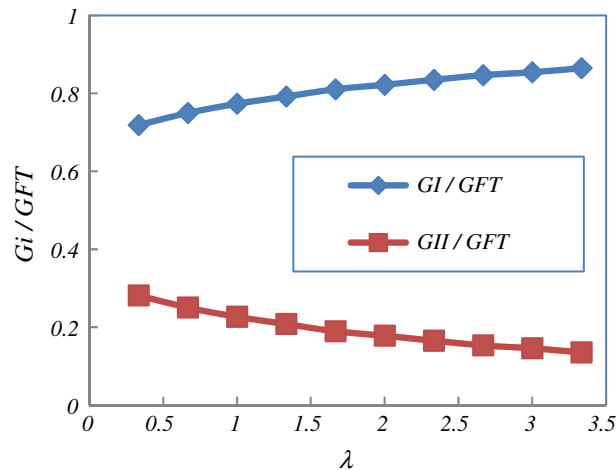
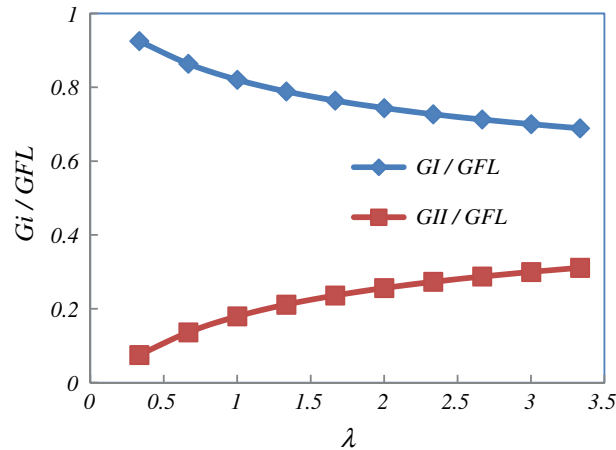

Figure 5 shows only numerical simulations of the strain energy release rate evolutions associated with longitudinal cracking. The analysis proposed is similar to the results exposed on the Figure 3, but for the estimation of the partial part of the strain energy associated with longitudinal damage. The result in Figure 6 shows that the part is attributed to the 0° on the strain energy release rate. This value is reported on Figure 5 (the green curve).

We can also observe that the strain energy release rates, G_{FT} and G_{FL} have similar variation laws. All the strain energy release rates are modelled by decreasing functions of the constraining parameter λ . For instance, in an eight-ply laminate, when the value of the constraining parameter λ is increased, the thickness of the 0° plies becomes greater. In this case, the fibres in the 0° plies carry most of the tensile loading, so the onset of the three different damage modes is delayed.

Figure 8. The onset of longitudinal cracks in a 8-ply laminate with constraining parameter λ is a result of the breaking modes G_I/G_{FL} , G_{II}/G_{FL} .



The main objective of this paper is to present results of an energy criterion to estimate the onset of several damage mechanisms. The proposed results are about numerical simulations pertaining to various approximations. These approximations concern the analysis of the strain energy release rate associated with the different damage mechanisms and fracture modes. In Table 2, the proposed analysis of the strain energy release rate, associated with the onset of transverse cracks and longitudinal cracks, is also related to the different loading modes (mode I (*opening mode*), mode II (*sliding mode*) and mode III (*tearing mode*)) which control the three types of damage. With this analysis (Figures 3 and 5), we can observe the part of each component of the stress tensor and their influence on the evolution of the damage. In Figures 7 and 8, the results of the numerical simulations show that transverse cracking and longitudinal cracking are initiated in opening mode (*mode I*). Numerous numerical simulations, with other materials and laminate architectures, give similar evolutions of cracking damage. The analysis of the strain energy release rate associated with the onset of the transverse and longitudinal cracks highlights the different modes that induce the two damage modes. Thus, thanks to the proposed numerical simulations, we can conclude that transverse cracking is mostly controlled by normal stress $\sigma_{xx}^{(90)}$, whereas longitudinal cracking is mostly controlled by normal stress $\sigma_{yy}^{(90)}$.

4. Conclusion

The purpose of this paper is to give an approximate expression of the strain energy release rate associated with each cracking mechanism and mode. The computation of the “partial” strain energy release rates is achieved as shown in Table 2. The related analysis was numerically assessed to understand and predict the most probable damage mechanism occurrence. In the type of the cross-ply laminates investigated, several damage mechanisms appear, these mechanisms can be followed with this kind of approach.

Using some simplified hypotheses, the relevant fracture mechanism and mode are predicted through a strain energy release rate criterion. From the proposed approach, several results can be obtained: it is confirmed that transverse matrix cracking is usually the first damage mechanism observed. In all the cases investigated, transverse cracking and longitudinal cracking are initiated in opening mode (*mode I*).

Funding

The author received no direct funding for this research.

Author details

Jean-Luc Rebière¹
 E-mail: jean-luc.rebiere@univ-lemans.fr

¹ Laboratoire d’Acoustique de l’Université du Maine, LAUM (UMR CNRS 6613), Université du Maine, Avenue Olivier Messiaen, 72085 Le Mans Cedex 9, France.

Citation information

Cite this article as: The initiation of transverse matrix cracking and longitudinal matrix cracking in composite cross-ply laminates: Analysis of a damage criterion, Jean-Luc Rebière, *Cogent Engineering* (2016), 3: 1175060.

References

Akshantala, N.-V., & Talreja, R. (2000). A micromechanics based model for predicting fatigue life of composite laminates.

- Materials Science and Engineering A*, 285, 303–313.
[http://dx.doi.org/10.1016/S0921-5093\(00\)00679-1](http://dx.doi.org/10.1016/S0921-5093(00)00679-1)
- Brewer, J.-C., & Lagace, P. A. (1988). Quadratic stress criterion for initiation of delamination. *Journal of Composite Materials*, 22, 1141–1155.
<http://dx.doi.org/10.1177/002199838802201205>
- Dakshina Moorthy, C. M., & Reddy, J. N. (1999). Recovery of interlaminar stresses and strain energy release rates in composite laminates. *Finite Elements in Analysis and Design*, 33(1), 1–27.
[http://dx.doi.org/10.1016/S0168-874X\(98\)00071-7](http://dx.doi.org/10.1016/S0168-874X(98)00071-7)
- Hinton, M. J., Kaddour, A. S., & Soden, P. D. (2004). Evaluation of failure prediction in composite laminates: Background to 'part C' of the exercise. *Composites Science and Technology*, 64, 321–327.
[http://dx.doi.org/10.1016/S0266-3538\(03\)00216-1](http://dx.doi.org/10.1016/S0266-3538(03)00216-1)
- Lemaître, J., & Chaboche, J.-L. (1988/1990). *Mécanique des matériaux solides* [Mechanics of solid materials] (Dunod 2nd ed.). Cambridge University Press.
- Mayes, J. S., & Hansen, A. C. (2004). A comparison of multicontinuum theory based failure simulation with experimental results. *Composites Science and Technology*, 64, 517–527.
[http://dx.doi.org/10.1016/S0266-3538\(03\)00221-5](http://dx.doi.org/10.1016/S0266-3538(03)00221-5)
- Nairn, J. A., & Hu, S. (1992). The initiation and growth of delaminations induced by matrix microcracks in laminated composites. *International Journal of Fracture*, 57, 1–24.
<http://dx.doi.org/10.1007/BF00013005>
- Ogihara, S., & Takeda, N. (1995). Interaction between transverse cracks and delamination during damage progress in CFRP cross-ply laminates. *Composites Science and Technology*, 54, 395–404.
[http://dx.doi.org/10.1016/0266-3538\(95\)00084-4](http://dx.doi.org/10.1016/0266-3538(95)00084-4)
- Pereira, A. B., de Morais, A. B., Marques, A. T., & de Castro, P. T. (2004). Mode II interlaminar fracture of carbon/epoxy multidirectional laminates. *Composites Science and Technology*, 64, 1653–1659.
<http://dx.doi.org/10.1016/j.compscitech.2003.12.001>
- Rebière, J.-L. (1992). *Modélisation du champ des contraintes créé par des fissures de fatigue dans un composite stratifié carbone/polymère* [Stress field modeling created by fatigue cracks in a composite laminate in carbon/polymer] (PhD thesis). Université de Poitiers.
- Rebière, J.-L., & Gamby, D. (2004). A criterion for modelling initiation and propagation of matrix cracking and delamination in cross-ply laminates. *Composites Science and Technology*, 64, 2239–2250.
<http://dx.doi.org/10.1016/j.compscitech.2004.03.008>
- Rebière, J.-L., Maâtallah, M.-N., & Gamby, D. (2001). Initiation and growth of transverse and longitudinal cracks in composite cross-ply laminates. *Composite Structures*, 53, 173–187.
[http://dx.doi.org/10.1016/S0263-8223\(01\)00002-2](http://dx.doi.org/10.1016/S0263-8223(01)00002-2)
- Wang, A. S. D., & Crossman, F. W. (1980). Initiation and growth of transverse cracks and edge delamination in composite laminates Part 1. An energy method. *Journal of Composite Materials*, 14, 71–87.
<http://dx.doi.org/10.1177/002199838001400106>
- Wang, A. S. D., Kishore, N. M., & Li, C. A. (1985). Crack development in graphite-epoxy cross-ply laminates under uniaxial tension. *Composites Science and Technology*, 24(1), 1–31.
[http://dx.doi.org/10.1016/0266-3538\(85\)90058-2](http://dx.doi.org/10.1016/0266-3538(85)90058-2)
- Xia, Z., Chen, Y., & Ellyin, F. (2000). A meso/micro mechanical model for damage progression in glass fiber/epoxy cross-ply laminates by finite-element analysis. *Composites Science and Technology*, 60, 1171–1179.
[http://dx.doi.org/10.1016/S0266-3538\(00\)00022-1](http://dx.doi.org/10.1016/S0266-3538(00)00022-1)



© 2016 The Author(s). This open access article is distributed under a Creative Commons Attribution (CC-BY) 4.0 license.

You are free to:

Share — copy and redistribute the material in any medium or format
Adapt — remix, transform, and build upon the material for any purpose, even commercially.
The licensor cannot revoke these freedoms as long as you follow the license terms.

Under the following terms:

Attribution — You must give appropriate credit, provide a link to the license, and indicate if changes were made.
You may do so in any reasonable manner, but not in any way that suggests the licensor endorses you or your use.
No additional restrictions

You may not apply legal terms or technological measures that legally restrict others from doing anything the license permits.



Cogent Engineering (ISSN: 2331-1916) is published by Cogent OA, part of Taylor & Francis Group.

Publishing with Cogent OA ensures:

- Immediate, universal access to your article on publication
- High visibility and discoverability via the Cogent OA website as well as Taylor & Francis Online
- Download and citation statistics for your article
- Rapid online publication
- Input from, and dialog with, expert editors and editorial boards
- Retention of full copyright of your article
- Guaranteed legacy preservation of your article
- Discounts and waivers for authors in developing regions

Submit your manuscript to a Cogent OA journal at www.CogentOA.com

